



## Specifications & Features

Model # CZC-HP-L01

Magnetic Latch

### Features

- Zinc alloy solid
- Reliable
- Magnetic Latch with Strike - Offset Handle
- Super magnetic, strong suction
- Chrome plated



CZC-HP-L01

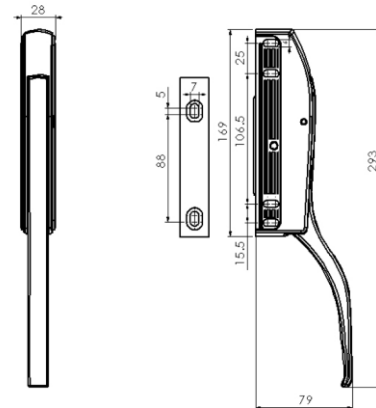

Dimensions

### Specifications:

**Size:** 11.5 1/2" x 3.1" x 1.1"

**Weight:** 3.75 lb

Note: Dimensions and Specification are subject to change without notice.



## Specifications & Features

Model # TM-1

Digital Thermometer

### Features

- Three character digital LED display
- Temperature between 0 F to 240 F
- Easy installation
- Reliable
- Water resistance
- Fault diagnosis indicator function



TM-1

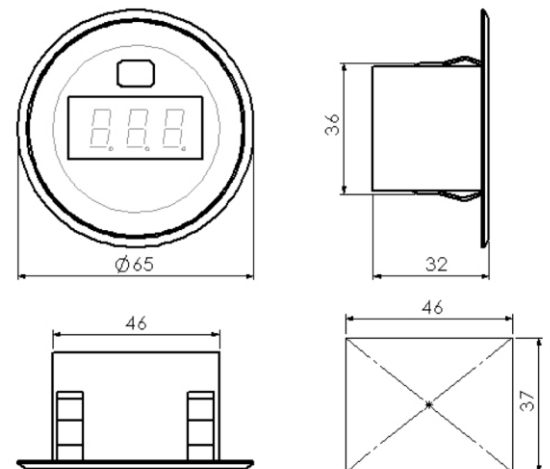

### Specifications:

**Operating Voltage:** AC120V, 60Hz

(Transformer Output AC 9V)

**Temperature Range:** 0 to 240F

**Precision:** ±1F

**Size:** 2 1/2" x 2 1/2" x 1 1/3"

**Cut-Size:** 2"W x 1 1/2" H

**Weight:** 7oz (included transformer)

Note: Dimensions and Specification are subject to change without notice.

