



Specifications & Features

Model # HPC 7011-WC9F9 (Donut)

Heater / Proofer Cabinet

Originally manufactured for the donut industry, this wider cabinet features a revolutionary, Multipurpose Rack System that offers a variety of options to fit a multitude of application. The new Rack System has two rack positions to choose from to fit your needs. At 3" spacing, Position 1 can hold 16 (24" x 24") pans. At Position 2, it can hold 32 (20"X12") or 16 (18" x 26") pans. It can even hold 18" & 22" pizza boxes! See Pg. 2 for more details. The cabinet has the ability to proof a variety of baked goods and allows them to rise before baking. Built-in all digital temperature controllers with easy set up enables you to choose a variety of temperatures including warming. Designed with enduring quality that protects your long term investment.

FEATURES:

- Designed for proofing and heating
- All digital display and controls
- Adjustable thermostat allows a variety of warming temperatures
- Provides cabinet holding temperature up to 180 F
- Water pan in base provides moisture for proofing
- Humidity up to 95% (under 90F)
- Clear polycarbonate door provides easy visibility
- Contains two safety-lock casters and two without for easy mobility
- Construction: Aluminum cabinet
- Limited manufacturer's warranty

Note: Dimensions and Specification are subject to change without notice.





Dimensions & Specifications

Model # HPC 7011-WC9F9

Heater / Proofer Cabinet

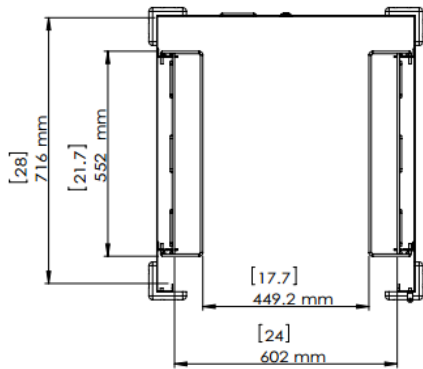

POSITION 1

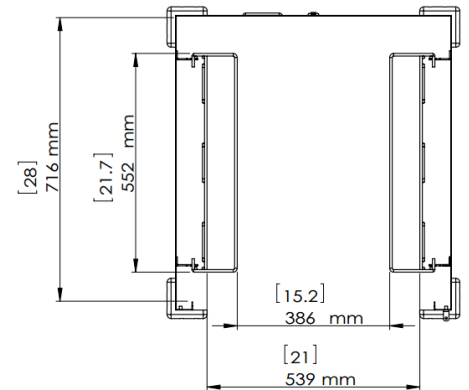
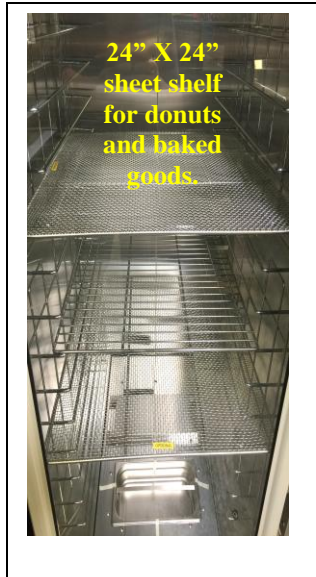

POSITION 2

18" x 26" Pan

22" Pizza Box



18" Pizza Box

22" Pizza Box



Electrical:	120 Volt, 60 HZ (1500 Watts) or 220 Volt, 50 HZ
Options:	Multipurpose Rack System.
Net Weight:	147 pounds
Gross Shipping Weight:	180 pounds
Dimensions:	31" W x 30" D x 67" H
Package:	33" W x 30" D x 74 ½" H
Note: Dimensions and specifications are subject to change without notice.	