



Specification

ER10(1B)

Countertop Food Warmer-Waterless

- ◆ Waterless design allow your convenient & safety Operation.
- ◆ No need water pan & water.
- ◆ Reduce operation & maintenance cost, unlike Traditional dry wells or steam table with water
- ◆ Stainless Steel Construction.
- ◆ Easy to clean.
- ◆ 6" deep open waterless pan.
- ◆ Individually controlled heating elements.
- ◆ Thermostatic heat controls and indicator lights.
- ◆ Limited manufacturers warranty .



Intertek
CONFORMS TO NSF/ANSI 4

NOTE: Dimensions and Specification are subject to change without notice



Specification
ER10(1B)
Countertop Food Warmer

Side View

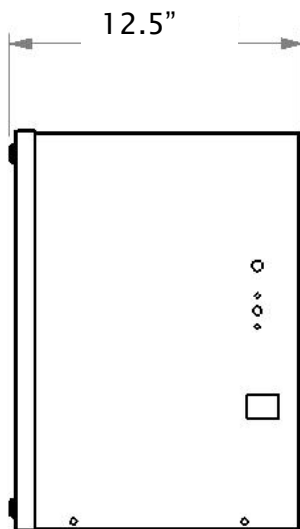

Top View

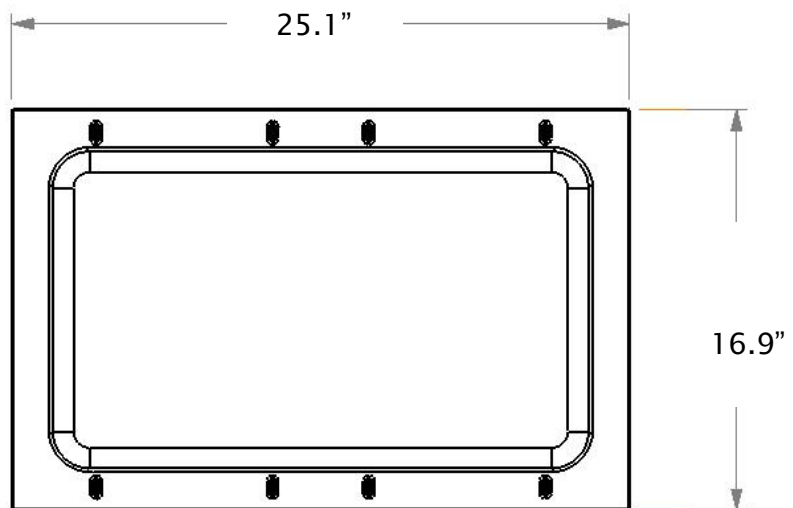

- Pan Capacity 20" x 10" x 6"
- Electrical 120 Volts, 4 Amps, 60Hz
- Power 550 Watts
- Cord NEMA 5-15P
- Net Weight 33 lbs(15 Kg)
- Gross shipping weight 40 lbs(18 Kg)
- Class 85
- Dimensions 25.1" W x 16.9" D x 12.5" H
- Package 26" W x 17" D x 13.5" H
- Warranty 1 Year Manufactures limited Warranty