

Specification

HPC7008-C9F8 Non-Insulated Heater Proofer



- ◆ Designed for proofing and heating.
- ◆ All digital display and controls.
- ◆ Machined Zinc Alloy handle.
- ◆ Adjustable thermostat for a variety of warming temperatures.
- ◆ Holding temperature up to 185 F.
- ◆ Water pan provides moisture for proofing
- ◆ Humidity up to 95%(under 90F)
- ◆ Total pan capacity is Thirty-two full size pan (18"x26")
- ◆ Clear polycarbonate door for easy viewing.
- ◆ High quality 5" casters, two with safety-lock
- ◆ Aluminum cabinet.



Note: Dimensions and Specification are subject to change without notice.



Intertek
CONFORMS TO NSF/ANSI 4

This full-size Heater Proofer cabinet can hold up to 32 18" x 26" full size pans, as well as a variety of others. Offering the ability to proof a variety of baked goods, allowing dough to rise before baking. All digital temperature controls with easy set up. Enables a variety of temperatures, including warming. Designed with enduring quality in mind.

Dimensions and Specifications

HPC7008-C9F8

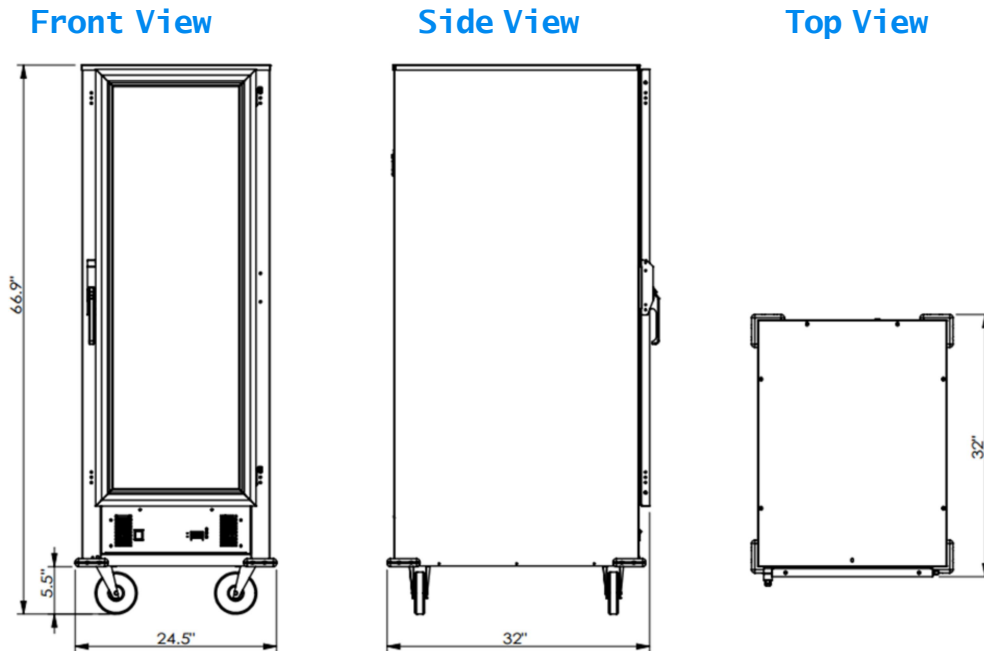

Pan capacity	32story, 18"x26" sheets
Electrical	120 volts
Power	1500 watts
Net weight	121 lbs.
Gross shipping weight	149 lbs.
Class	100
Dimensions	24.5"W X 32" DX 66.9" H
Package	24"W X 33" D X 67" H
Warranty	1Year Manufactures limited Warranty