



Specification

HPC7008UC-C9S1

Non-Insulated Heater Proofer

- ◆ Designed for proofing and heating.
- ◆ All digital display and controls.
- ◆ Machined Zinc Alloy handle
- ◆ Adjustable thermostat for a variety of warming temperatures.
- ◆ Holding temperature up to 185 F.
- ◆ Water pan provides moisture for proofing
- ◆ Humidity up to 95%(under 90F)
- ◆ Adjustable & Universal Rack System.pan Capacity is 9 story 18"x 26"
- ◆ Clear polycarbonate door for easy viewing.
- ◆ High quality 5" casters,two with safety-lock
- ◆ Aluminum cabinet.



Intertek
CONFORMS TO NSF/ANSI 4

Note: Dimensions and Specification are subject to change without notice.

This 31" under counter heater proofer, is energy efficient, space savings, ADA compliant cabinet, ideal when space is a concern. Featuring a universal and adjustable pan rack system. Offering the ability to proof a variety of baked goods, allowing dough to rise before baking. All digital temperature controls with easy set up. Enables a variety of temperatures, including warming. Designed with enduring quality in mind.

Dimensions and Specifications



HPC7008UC-C9S1

Front View

Side View

Top View

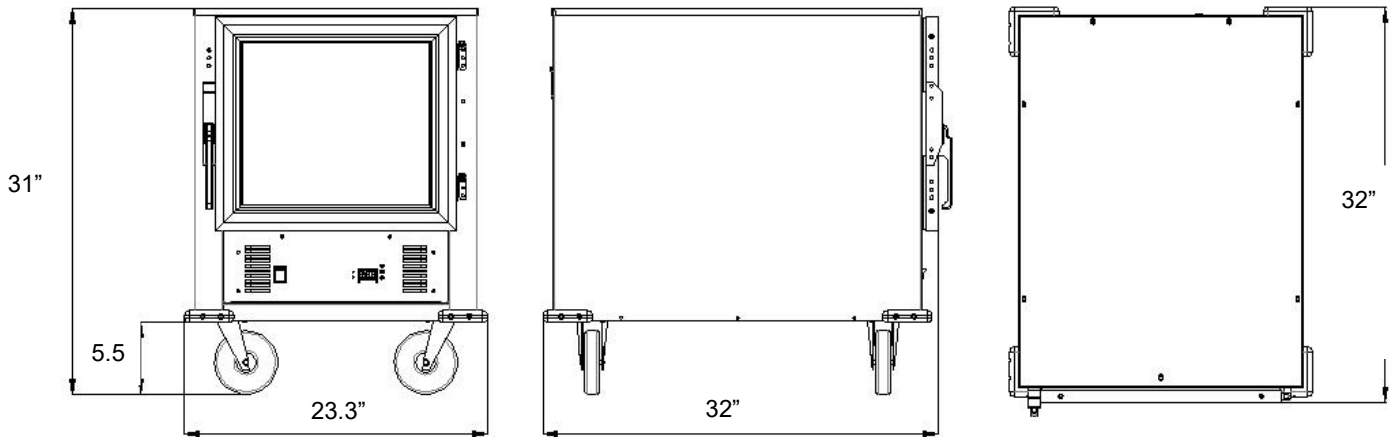

Pan Capacity	9story, 18"x26" in 1 -1/2" Increments.
Electrical	120 Volts
Power	1500 Watts
Net weight	83 lbs (38kg)
Gross shipping weight	106 lbs (48kg)
Class	100
Dimensions	23.3" W x 32"D x 31" H
Package	24" W x 33"D x 32" H
Warranty	1 Year Manufactures limited Warranty