

# Specification

## HPC7011-C9F9



### Non-Insulated Universal Heater Proofer

- ◆ Designed for proofing and heating.
- ◆ All digital display and controls.
- ◆ Machined Zinc Alloy handle.
- ◆ Adjustable thermostat for a variety of warming temperatures.
- ◆ Holding temperature up to 185 F.
- ◆ Water pan provides moisture for proofing
- ◆ Humidity up to 95%(under 90F)
- ◆ Universal rack system can hold both full size Sheet pans (18"x26") as well as hotel steam Pans.
- ◆ Clear polycarbonate door for easy viewing.
- ◆ High quality 5" casters, two with safety-lock
- ◆ Aluminum cabinet.



**Note: Dimensions and Specification are subject to change without notice.**



**Intertek**  
CONFORMS TO NSF/ANSI 4

This full-size Heater Proofer cabinet can hold up to 16 18" x 26" full size pans, as well as a variety of others. Offering the ability to proof a variety of baked goods, allowing dough to rise before baking. All digital temperature controls with easy set up. Enables a variety of temperatures, including warming. Designed with enduring quality in mind.

# Dimensions and Specifications



## HPC7011-C9F9 Universal Rack System

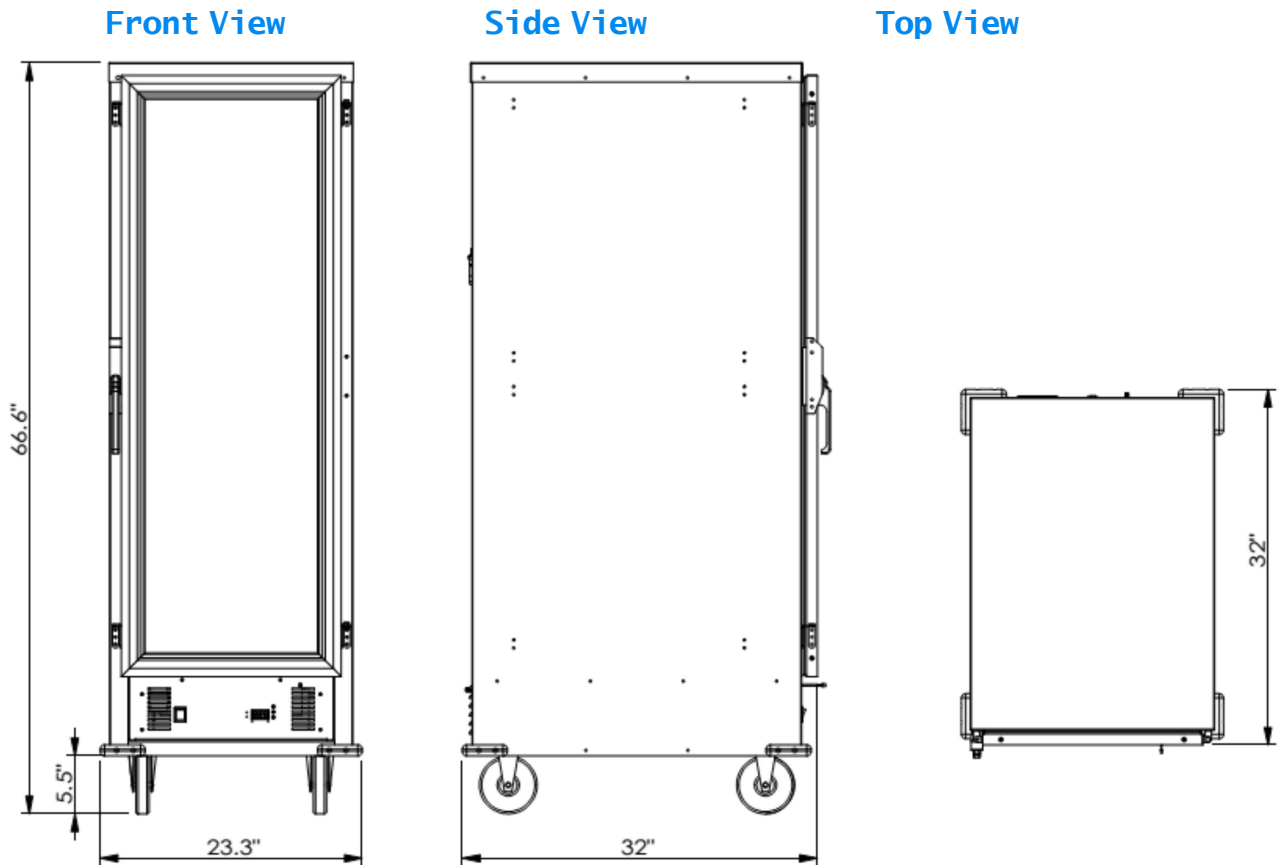

Pan capacity Universal Rack system  
16pan capacity, 18"x26", 12"x20",  
16"X20", 13"X18", 14"X18"  
Holds up to 18" Pizza Box Accommodates hotel pans

Options None

Electrical 120 volts

Power 1500 watts

Net weight 122 lbs.

Gross shipping weight 150 lbs.

Class 100

Dimensions 23.3" W X 32" D X 66.6" H

Package 24" W X 33" D X 67" H

Warranty 1 Year Manufactures limited Warranty