

Specification



HPC7013HFSD Insulated Cook and Hold Oven

- ◆ Designed for cooking and holding.
- ◆ Digital Electronic controls,select a variety Of cooking temperatures & time.
- ◆ Digital Timer to notify user when process is complete.
- ◆ Cooks by time and automatically converts From cook mode to hold mode.
- ◆ Control features indicator lights for the cook cycle and hold function.
- ◆ Side racks with fifteen pan positions spaced on 1 1/2"(38mm)centers, per compartment.
- ◆ Solid door with magnetic door latch,Zinc Alloy machined handle.
- ◆ Heavy duty 5"casters,two swivel with brakes, two rigid.provides mobility when fully loaded
- ◆ Maximum temperature 325F.
- ◆ Made of stainless steel.



Intertek
CONFORMS TO NSF/ANSI 4

[Note:Dimensions and specification are subject to change without notice.](#)

This Energy Efficient half size oven has a controlled, uniform heat source that maintains close temperature tolerances throughout the cooking and holding function. As a result, consistent cooking offers low shrinkage of bulk or portion-cut protein items, higher food moisture content, and significantly longer holding life. Max temperature 325 degrees °F.

Specifications and Dimensions

HPC7013HFSD



Front View

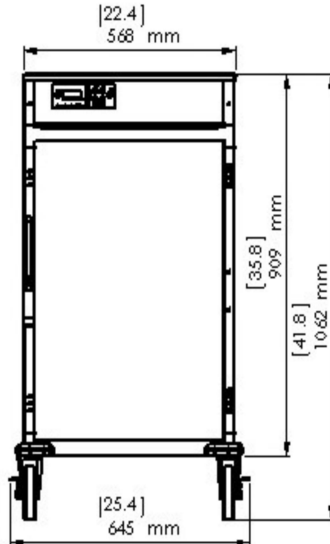

Side View

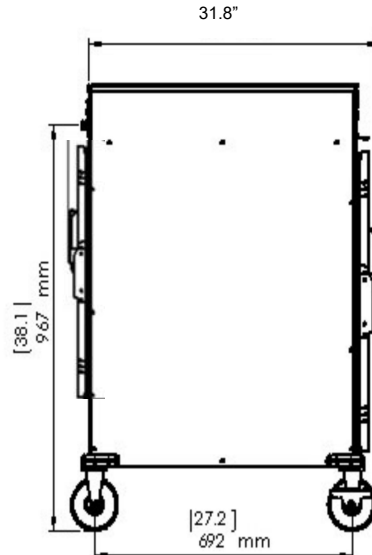

Top View

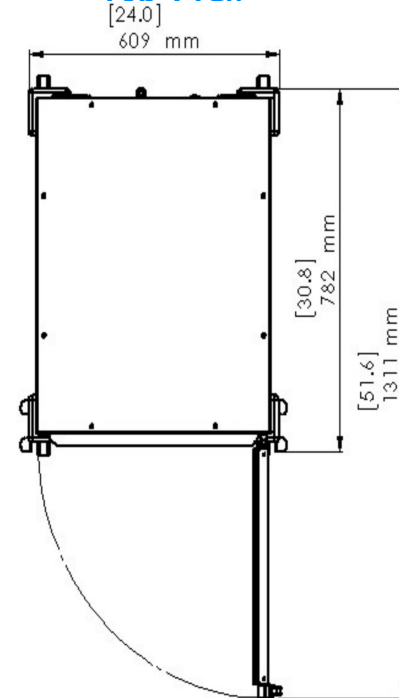

Pan capacity	18"x26"X 1" 1 5 pcs 20"x 12"x2- 1/2"8pcs 20"x12"x4"4pcs 20"x 12"x6"4pcs
Electrical	208 volts, 14.5Amps, 60HZ
Power	3200 watts
Cord	Included. Need plug end, installed by qualified electrician.
Net weight	210 lbs (95kg)
Gross shipping weight	235 lbs (107kg).
Class	100
Dimensions	25.4"W X 31.8 " D X 41 .8" H
Package	26"WX33"DX42"H
Warranty	1 Year manufactures limited Warranty