

Specification

HPC7101HF-C9F8 Insulated Heater Proofer



- ◆ Designed for proofing and heating.
- ◆ All digital display and controls.
- ◆ Machined Zinc Alloy handle.
- ◆ Adjustable thermostat for a variety of warming temperatures.
- ◆ Holding temperature up to 185 F.
- ◆ Water pan provides moisture for proofing.
- ◆ Humidity up to 95%(under 90F) .
- ◆ Total pan capacity is sixteen full size pan (18" x 26").
- ◆ Clear polycarbonate door for viewing.
- ◆ High quality 5" casters, two with safety lock
- ◆ Aluminum cabinet.



Intertek
CONFORMS TO NSF/ANSI 4

Note: Dimensions and Specification are subject to change without notice.

This Half-size Heater proofer cabinet can hold up to seventeen, 18"x 26" full size pans, as well as a variety of others. offering the ability to proof a variety of baked goods, allowing dough to rise before baking. All digital temperature controls with easy set up. Enables a variety of temperatures, including warming. Designed with enduring quality in mind.

Dimensions and Specifications

HPC7101HF-C9F8



Front View

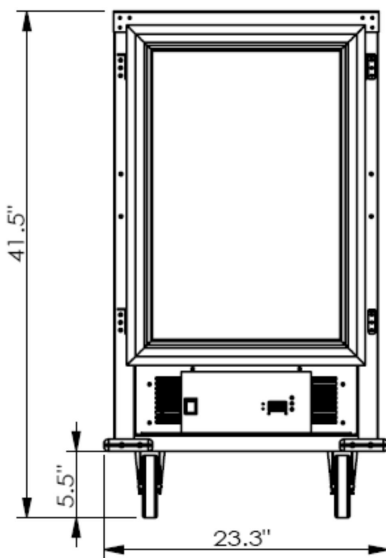

Side View

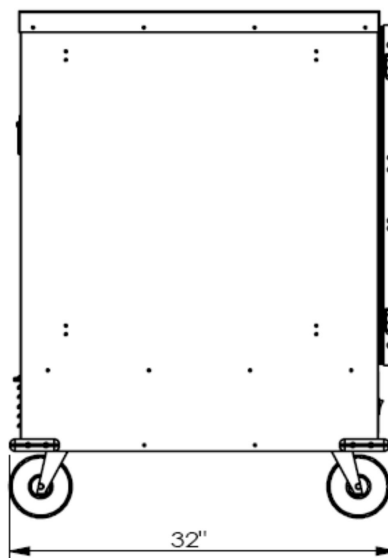

Top View

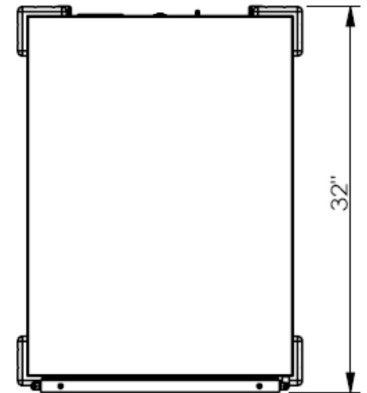

Pan capacity 16 story 18" x26" sheets

Electrical 120 volts

Power 1500 watts

Net weight 161 lbs.

Gross shipping weight 187 lbs.

Class 100

Dimensions 23.3"W X 32" D X 41.5" H

Package 25"W X 33" D X 42" H

Warranty 1Year Manufactures limited warranty