

Specification

HPC7101HF-SF8

Non-Insulated Heater Proofer



- ◆ Designed for proofing and heating.
- ◆ All digital display and controls.
- ◆ Machined Zinc Alloy handle
- ◆ Adjustable thermostat for a variety of warming temperatures.
- ◆ Holding temperature up to 185 F.
- ◆ Water pan provides moisture for proofing
- ◆ Humidity up to 95%(under 90F)
- ◆ Total pan capacity is Sixteen story,full size pan (18"x 26")
- ◆ High quality 5" casters,two with safety-lock
- ◆ Aluminum cabinet.
- ◆ Stainless steel solid door



Note: Dimensions and Specification are subject to change without notice.



Intertek
CONFORMS TO NSF/ANSI 4

This Half-size Heater Proofer cabinet can hold up to sixteen, 18" x 26" full size pans, as well as a variety of others. Offering the ability to proof a variety of baked goods, allowing dough to rise before baking. All digital temperature controls with Easy set up. Enables a variety of temperatures, including warming. Designed with enduring quality in mind.

Dimensions and Specifications

HPC7101HF-SF8

Front View

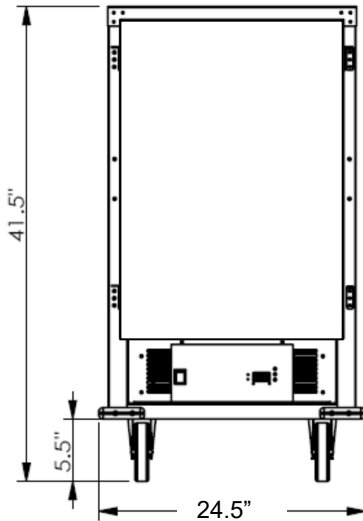

Side View

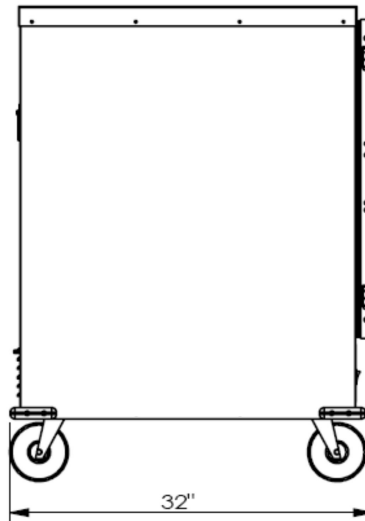

Top View

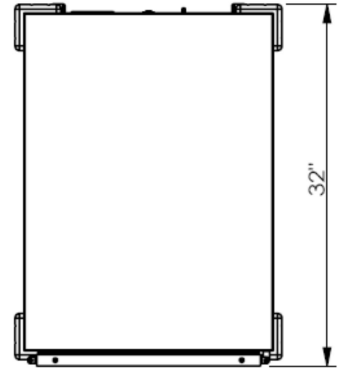

Pan capacity 16shelves/stories, 18"x26" sheets

Electrical 120 volts

Power 1500 watts

Net weight 161 lbs.

Gross shipping weight 187 lbs.

Class 100

Dimensions 24.5"W X 32" DX 41 .5" H

Package 25"W X 33" D X 42" H

Warranty 1Year Manufactures limited Warranty