

Specification

PW5002-3 Warmer Merchandiser



- ◆ Easy to clean.
- ◆ Aluminum cabinet.
- ◆ Tempered glass side and door panels
- ◆ Designed for holding precooked specialty foods
- ◆ Two clear glass doors front or rear counter applications
- ◆ Adjustable chrome-plated racks can placed flat or sloped.
- ◆ Adjustable thermostat 450-watt element temperature up 160°F.



Note: Dimensions and specification are subject to change without notice.



Intertek

CONFORMS TO NSF/ANSI 4

COZOC 2-Door warmer merchandiser is designed for counter applications. The operator side has controls and a door for easy loading. The consumer side has a door for self-serve. Features an adjustable thermostat with a circulating fan, three adjustable chrome-plated racks can that be placed flat or sloped and are removable for easy cleaning. stainless steel and Aluminum construction provides durability and ease of cleaning.

Dimensions and Specifications

PW5002-3



Front View

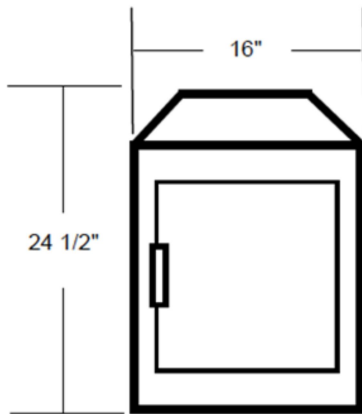

Side View

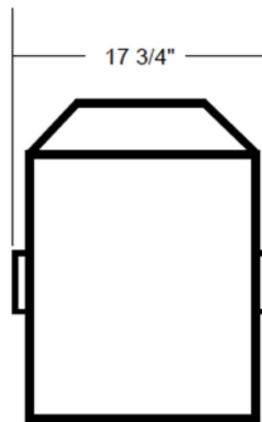

Top View

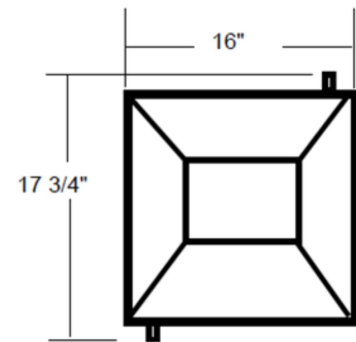

Options None

Electrical 120volts, 60 HZ

Power 450 watts

Net weight 39 lbs.

Gross shipping weight 42 lbs.

Class 85

Dimensions 16" W X 17.75" DX 24.5" H

Package 17.75" W X 19.75" DX 25" H

Warranty 1 Year Manufactures limited Warranty