

Specification

ST5005E-2

2 Well Steam Table



- ◆ Easy to clean.
- ◆ Stainless Steel Construction.
- ◆ Uses Edgeless Water pan.
- ◆ ½" polyethylene cutting board.
- ◆ Adjustable stainless-steel legs.
- ◆ Thermostatic heat controls and indicator lights.
- ◆ 8" deep open well design fits full size spillage pans.
- ◆ Individually controlled 500W tubular heating elements.



Intertek
CONFORMS TO NSF/ANSI 4

Note: Dimensions and Specification are subject to change without notice.

Cozoc's 8" deep open well steam table features individual bays (uses edgeless water pan), each with independent temperature controls perfect for maintaining hot foods. Adjustable unit height, constructed of stainless steel with four stainless-steel legs and stainless-steel under shelf, 1/2" thick polyethylene cutting board for workspace. Individually controlled 500W tubular heating elements in each bay assuring proper holding temperatures

Dimensions and Specifications

ST5005E-2



Front View

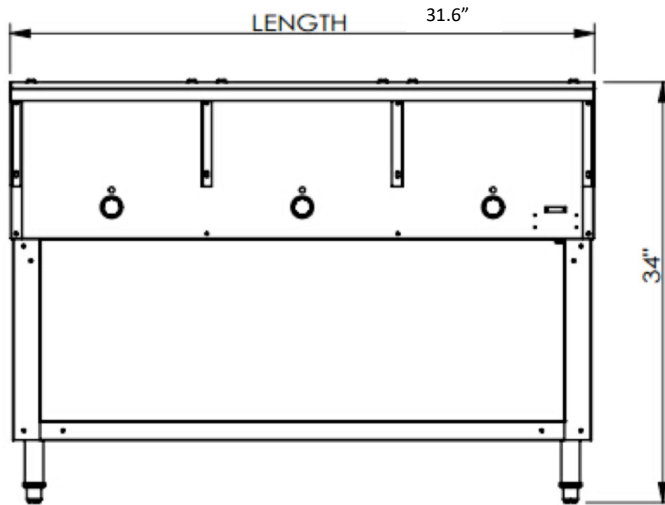

Side View

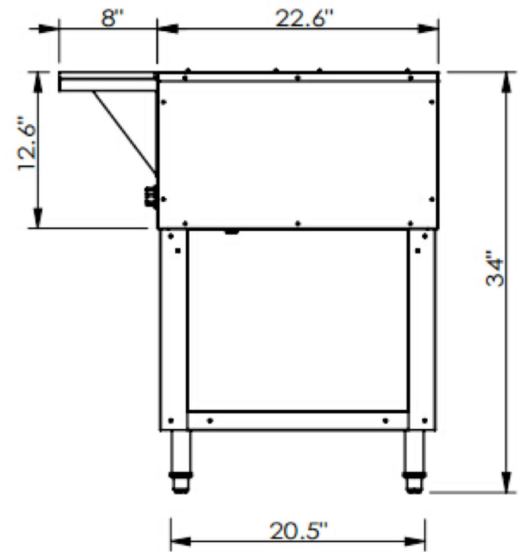

Pan	Use edgeless water pan
Options	None
Electrical	1 20 Volts
Power	1000 Watts
Net weight	79 lbs.
Gross shipping weight	88 lbs.
Class	1 00
Dimensions	31.6" W X 30.6" D X 34" H
Package	35 " W X 26" D X 19" H
Warranty	1Year Manufactures limited warranty